

How to Design a 240 W, Universal AC Input, 1.1 W/cm³ Power Density eGaN® FET USB PD3.1 Power Supply



Introduction

EPC recently introduced the **EPC9171** [1], a GaN FET based USB power supply meeting the USB PD3.1 standard. With a universal input and 48 V output it can deliver up to 240 W and achieve 92% peak efficiency under both 120 V_{RMS} and 230 V_{RMS} input and 72 °C temperature rise (around the rectifier FETs). The high voltage stages adopt 650 V GaN FETs while secondary stage comprises of a pair of eGaN® FETs EPC2218 with total die size of only 13.5 mm². The introduction of eGaN technology enabled power density and efficiency as demonstrated by the experimental results.

System overview

This application note presents the design of a low stage count approach for a universal AC voltage Input to 15 V through 48 V DC output with load current limit of 5 A suitable for USB PD3.1 power supplies and demonstrated with the EPC9171 demonstration board with support for operation in Extended Power Range (EPR) Mode. A power density of 1.1 W/cm³ was achieved by employing GaN devices, operated at high switching frequencies, in both the primary and secondary circuits.

Design of a universal AC input to output USB PD3.1 power supply

AC input power supplies require a PFC front end AC to DC converter to meet AC grid harmonic requirements, an isolation stage to meet safety requirements, and post regulator to meet load requirements. Each converter stage adds losses and increases the overall size of the converter. The design of the EPC9171 takes a unique approach to achieve high power density and high efficiency by employing an interleaving boost converter PFC [2] stage followed by an isolated LCC [3] resonant power stage as shown in Figure 1.

The interleaving PFC stage ensures high power factor and low AC line current harmonics to meet the harmonics requirements of the EMC standards such as IEC 61000-3-2 / Class A. It supports full-power operation over a wide input voltage range of 90 – 265 V_{RMS}, while optimizing the light load efficiency by means of load dependent PFC phase control. The Critical Conduction Mode (CrCM) operation of the PFC stage in combination with 650 V GaN power switches [4] enable high-frequency operation well above 200 kHz. The power density advantage is gained by the elevated switching frequency that requires small physical dimension PFC inductors.

The LCC resonant power stage [3], operated from the pre-regulated PFC bus voltage, provides both the galvanic isolation and the output voltage/current regulation. Unlike the well-known LLC resonant power stages, which suffers from limited output voltage range, the LCC resonant converters are ideal for wide output voltage range applications with limited switching frequency variation, that also features superior constant-current characteristics. The LCC resonant converter also utilizes 650V GaN switches in primary high voltage circuit in this design and operates in the frequency range of 350 to 580 kHz, which helps to reduce the size of the power transformer as well as that of the other passive components in the resonant circuit. The output voltage is variable over the whole Adjustable Voltage Supply (AVS) range of 15 V through 48 V as specified by the corresponding USB PD3.1 standard, when operating in constant voltage (CV) mode. A constant current (CC) mode with precise current control ensures that the output current never exceeds the selected current limit (5 A max.).

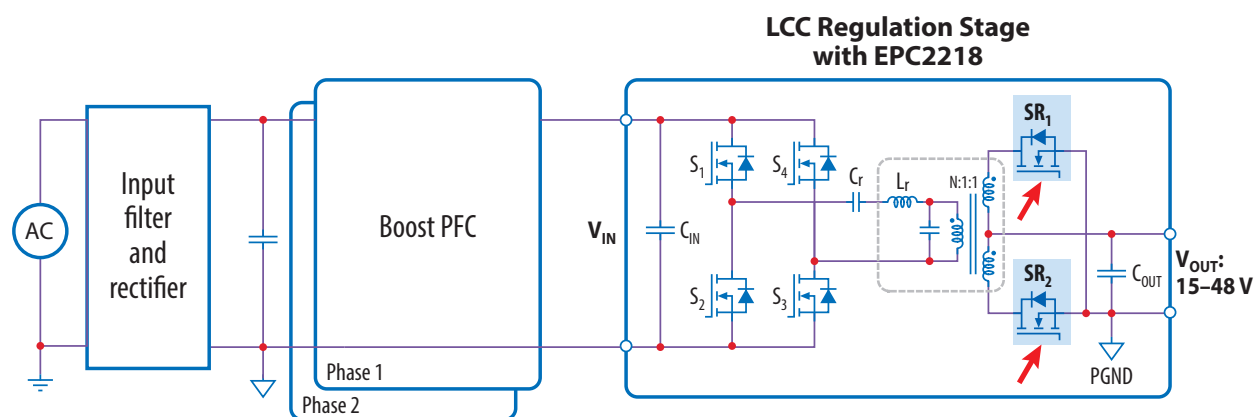

Figure 1. EPC9171 system block diagram.

Table 1: Electrical Characteristics ($T_A = 25^\circ\text{C}$) EPC9171

Symbol	Parameter	Min	Typ	Max	Units
V_{IN}	Input voltage	90		265	$V_{AC_{RMS}}$
V_{OUT}	Output voltage ⁽¹⁾	15		48	V_{DC}
ΔV_{OUT}	Output voltage ripple		100		mV
I_{OUT}	Output current ⁽¹⁾			5	A
f_s	Switching frequency	350		580	kHz
PF	Power Factor (120 VAC/60 Hz)		0.991		
THD	THD[%] (120 VAC/60 Hz)		12.7		%

(1) Variable adjustable

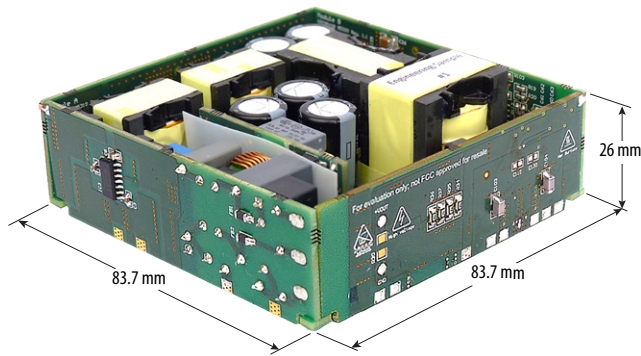

Figure 2. EPC9171 240 W USB-C charger demo board.

As part of the LCC converter, a synchronous rectifier stage employs a pair of 100 V rated, 3.2 mΩ, EPC2218 GaN switches [5] on the secondary side. The GaN switches are driven by fast synchronous rectifier controllers to minimize the losses over the whole output voltage and current range and allow a simple yet effective thermal design.

The specifications for the USB PD 3.1 power supply are given in Table 1.

Experimental validation

The EPC9171 was designed and built as shown in Figure 2 and various tests conducted that include efficiency and power loss and AC harmonic measurements at various input voltage and load conditions.

Measured efficiency and power losses

In Figures 3-4, power efficiency was measured over a output current range of 1-5 A at 15 V, 20 V, 28 V, 36 V and 48 V output voltages, and at 120 VAC_{RMS} and 230 VAC_{RMS} input voltages, respectively. The input power was measured by an AC power analyzer, while DC output parameters were recorded by precision digital multimeters.

AC performance

AC line parameters were measured with an AC power analyzer at 48 V / 5 A and 48 V / 2.5 A load, and at 120 VAC_{RMS} and 230 VAC_{RMS} input voltages, respectively. Line harmonics were evaluated and compared against the IEC 61000-3-2 / CLASS A line harmonic current limits in Figure 5. Only full-power load measurements are shown.

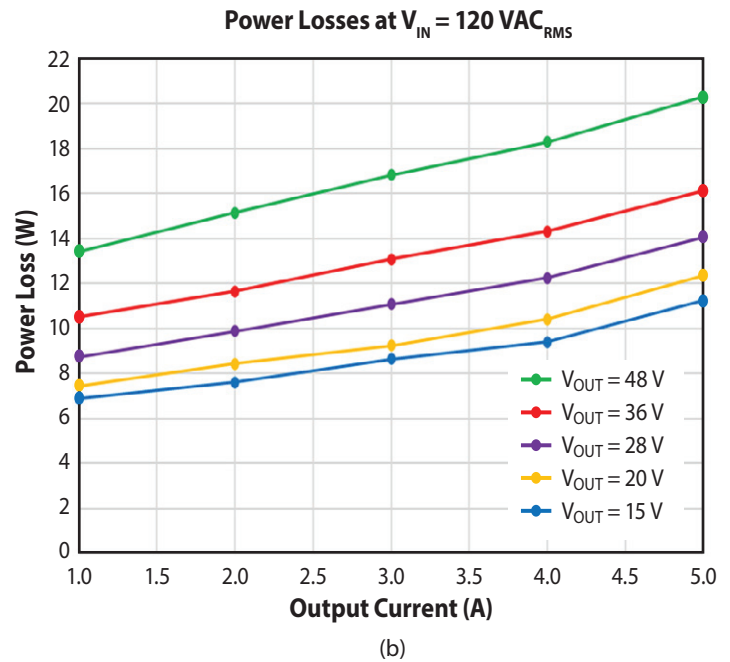
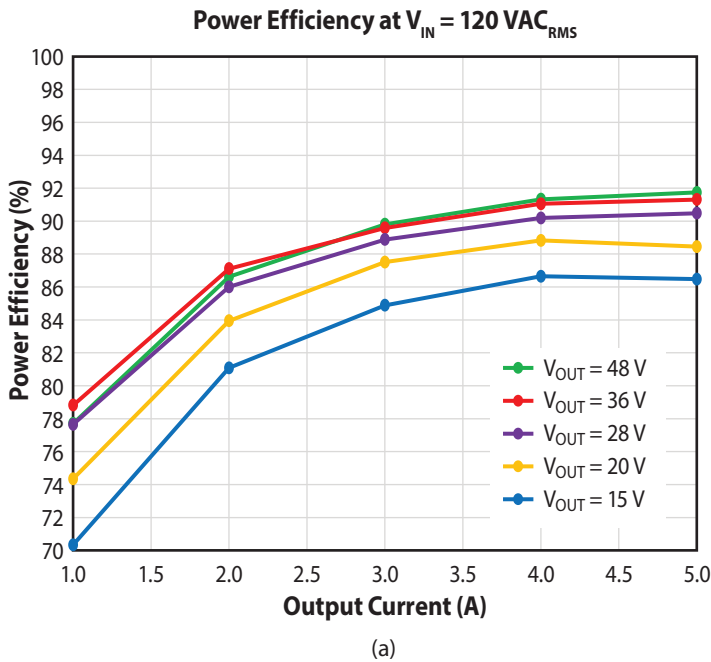

Figure 3. Typical efficiency (a) and power losses (b) for various output voltages with $V_{IN} = 120\text{ VAC}_{RMS}$.

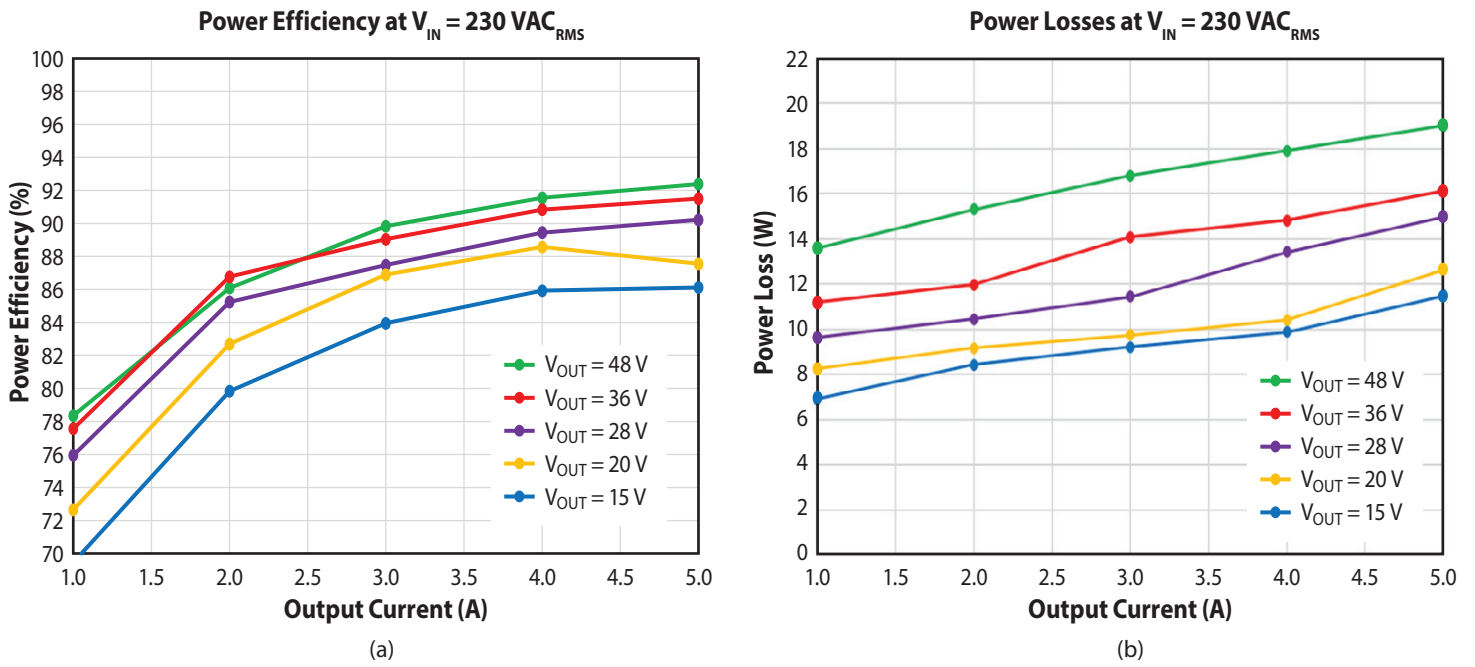
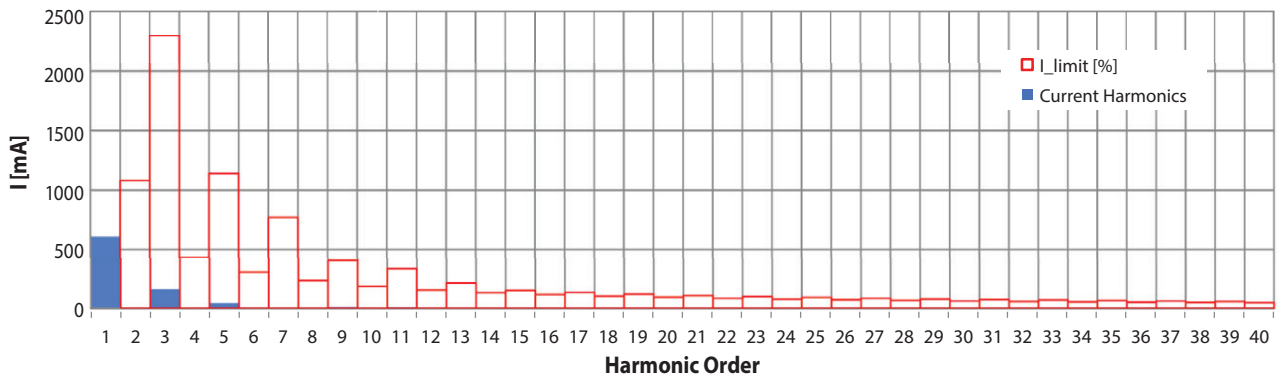

Figure 4. Typical efficiency (a) and power losses (b) for various output voltages with $V_{IN} = 230 \text{ VAC}_{RMS}$.

(a) Current harmonics at $V_{IN} = 120 \text{ VAC}_{RMS} / 60 \text{ Hz} / P_{OUT} = 240 \text{ W}$, 48 V/5000 mA



(b) Current harmonics at $V_{IN} = 230 \text{ VAC}_{RMS} / 50 \text{ Hz} / P_{OUT} = 240 \text{ W}$, 48 V/5000 mA

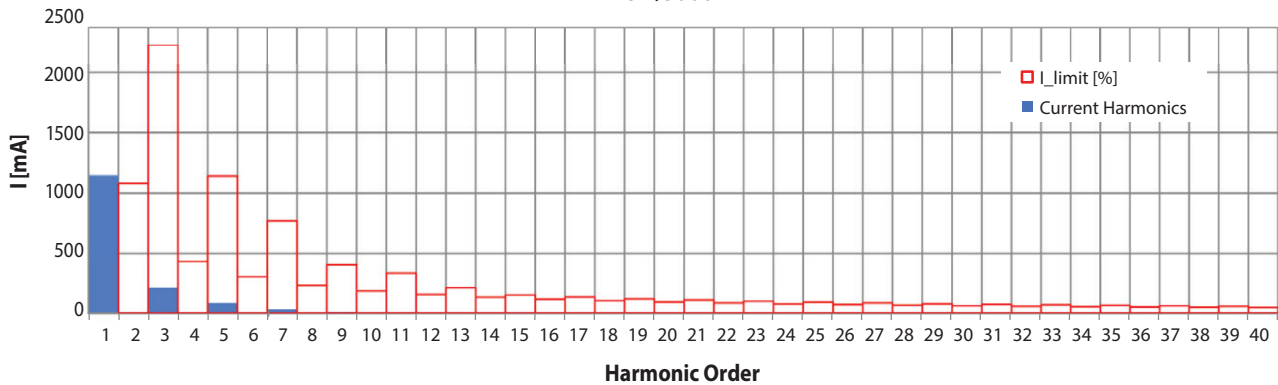
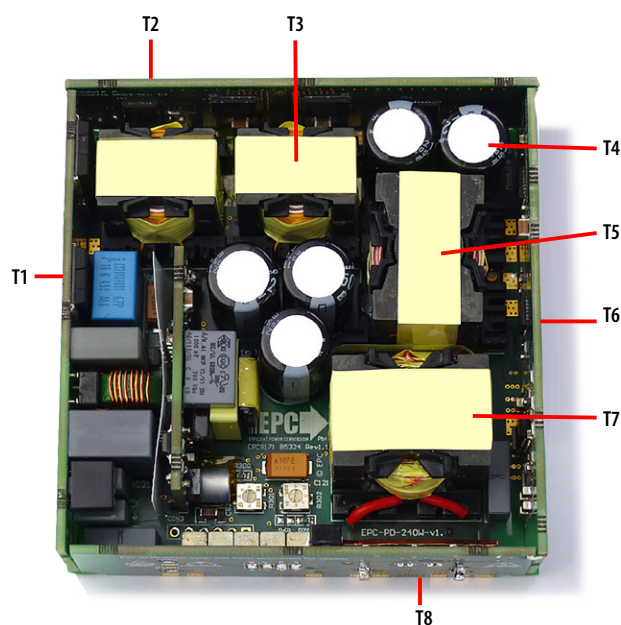

Figure 5. (a) Measured current harmonics. $V_{IN} = 120 \text{ VAC}_{RMS} / 60 \text{ Hz}$. (b) Measured current harmonics. $V_{IN} = 230 \text{ VAC}_{RMS} / 50 \text{ Hz}$.



Input: 230 VAC/50 Hz or 120 VAC/60 Hz

Output: 48 V/5 A

Test interval: 10 min

Tamb: 21°C

Notes: DUT placed on 20 mm distance holders to ensure some airflow underneath

Location	Description	Max. temperature 120 VAC/60 Hz	Max. temperature 230 VAC/50 Hz
T1	Input active rectifier	68°C	51°C
T2	PFC switch (IC1)	75°C	77°C
T3	PFC inductor (L5)	81°C	65°C
T4	PFC bus capacitor (C99)	73°C	72°C
T5	LCC resonant inductor (L2)	94°C	95°C
T6	LCC switch (IC6)	93°C	94°C
T7	Transformer (T1)	97°C	96°C
T8	Output sync. rectifier (Q5/Q6)	89°C	90°C

Figure 6. Thermal performance when operating from 120 VAC_{RMS} and 230 VAC_{RMS} input and delivering 5 A into 48 V in an ambient of 21°C.

Thermal performance

Temperature measurement from IR camera from the bottom of the PCB is shown in Figure 6.

Conclusion

48 V is increasingly being adopted in computing data centers and now consumer electronics such as laptops. The new USB PD3.1 [6] standard is also making inroads into laptops driven in part by the increase in USB voltage to 48 V that increases the total power delivery up to 240 W given a current limit of 5 A for the connectors and cables. Compatible power supplies using the new USB PD standard also face increasing pressure to yield a small form factor solution driving the need for high power density. The fast-switching speed and low R_{DSon} of GaN FETs address this challenge [7] in multiple circuits that make up the power supply.

References

- [1] EPC9171 Quick Start Guide [online] Available at: <<https://epc-co.com/epc/Products/DemoBoards/EPC9171.aspx>> [Accessed 07 March 2022].
- [2] O'Loughlin, M. (2006, March 30). Advantages of interleaved boost converters for PFC. EDN. Retrieved March 4, 2022, from <https://www.edn.com/advantages-of-interleaved-boost-converters-for-pfc/>
- [3] Survey of resonant converter topologies - ti.com. (n.d.). Retrieved March 4, 2022, from <https://www.ti.com/seclit/ml/slup376/slup376.pdf>
- [4] NV6128 datasheet. Navitassemi.com. 2022. [online] Available at: <https://www.navitassemi.com/wp-content/uploads/2020/07/NV6128_Datasheet_Final-12-29-2020.pdf> [Accessed 4 March 2022].
- [5] EPC2218 Datasheet[online] Available at: <<https://epc-co.com/epc/Products/eGaNfetsandICs/EPC2218.aspx>> [Accessed 28 February 2022].
- [6] Usb.org. 2022. USB Power Delivery | USB-IF. [online] Available at: <<https://usb.org/document-library/usb-power-delivery>> [Accessed 21 February 2022].
- [7] A. Lidow, M. De Rooij, J. Strydom, D. Reusch, and J. Glaser, **GaN Transistors for Efficient Power Conversion, 3rd ed.** John Wiley & Sons, 2019. ISBN: 978-1119594147.

For More Information

Please contact info@epc-co.com or your local sales representative

Visit our website: epc-co.com

Sign-up to receive EPC updates at bit.ly/EPCupdates or text "EPC" to 22828



eGaN is a registered trademark of Efficient Power Conversion Corporation

